



Upright Microscope
ECLIPSE
Ni

See the evolution

The Ni series, the ultimate in upright biological microscope evolution, supports bioscience studies with enhanced basic performance and flexible system expandability.

The newly developed CFI Plan Apochromat λ (lambda) series objectives are the key to the series' optical performance. Nano Crystal Coat, with its ultra low refractive index, is employed for the first time in microscope objectives, providing brighter, high-resolution and high-contrast microscopy images.

Nikon's proprietary stratum structure, used and highly acclaimed for inverted research microscopes, is now incorporated in an upright microscope, allowing a combination of components to be installed.

Applications using laser and fluorescent proteins, such as Kaede and PA-GFP, are possible with the addition of a two-tiered fluorescent unit and a photoactivation unit.

The Ni series transcends the concept of conventional upright microscopes and expands the possibilities of advanced research in fields such as bioscience and medicine.

Ni

■ System expandability

- Nikon's proprietary stratum structure enables efficient system construction.
- The numerous accessories can be custom combined depending upon application.

■ Optical performance

- CFI Plan Apochromat λ objectives with chromatic aberration correction and high transmission throughout a broad range of wavelengths
- Objectives with improved transmission in near IR wavelength range for multiphoton excitation imaging

■ Design

- 3D ergo design combines functionality with sophistication.

■ Operability

- Ni-E: Motorized model with automatic changeover of observation methods and adjustment of microscope accessories.
- Ni-U: Manual model with some motorized options.
- Most microscope controls can be operated with easy-to-reach buttons on the front of the Ni-E.



The Ni series microscopes meet all research demands

These microscopes have three features: expandability of the system due to the stratum structure that enables optical paths in two tiers; superior optical performance, as represented by the Plan Achromat λ series objectives; and high-speed motorized accessories. The Ni series is designed to meet the needs of all advanced bioscience and medical research.

Cell biology

Immunology

Genetics

Microbiology

Pathology

Neuroscience

Drug discovery

Developmental biology

Cancer research

Microscopy images courtesy of:
(Left) Torsten Whitmann's
(Center) Michael W. Davidson
(Right) Dr. Jennifer Waters and Adrian Salic

Expandable system broadens application possibilities

Multi-color fluorescent imaging (Ni-E)

Demand for multi-color fluorescent imaging that uses newly developed fluorescent proteins and fluorescent reagents is constantly increasing. Nikon meets such needs with diverse functions and optical technologies.

High-speed motorized components

The higher speeds of the motorized excitation and barrier filter wheel and the motorized shutter enable quick wavelength changes, reducing photobleaching of the specimen. It can be operated via easily accessible control buttons, increasing operation efficiency.

CFI Plan Apochromat λ series objectives

Transmission and chromatic aberration correction have been improved throughout the wide range of visible to near IR wavelengths, allowing use of various fluorescent reagents. They provide bright, high-contrast, high S/N (signal-to-noise) ratio multi-color fluorescence images with almost no focus shift when used with any wavelength.

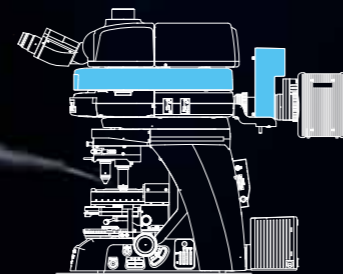

Mounted motorized excitation/barrier filter wheel

Ni-E

Multi-color
fluorescent
observation

FISH

Signal
conversion

Photo-activation imaging (Ni-E/Ni-U)

Research into the reactions and changes of stimulated cells has become popular in recent years. Nikon has developed a new photoactivation unit for upright microscopes, a first in microscopy.

Flexible stratum structure

This structure allows two-layer mounting of a photoactivation unit with an epi-fluorescence cube turret.

Objectives for long-wavelength laser

With CFI Plan Apochromat λ objectives, chromatic aberration has been corrected up to 850 nm and transmission improved in the long wavelength range, increasing accuracy and efficiency of laser excitation at target site.

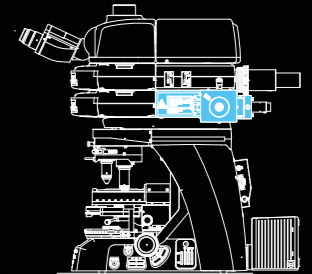

Mounted photoactivation unit

Ni-E

Ni-U

Photo
activation

FRAP

Multiphoton imaging (Ni-E)

Multiphoton microscopy in which long excitation wavelengths are used to allow less-invasive imaging of ever deeper areas of cells is gaining popularity. The design of the Ni-E model is optimized for multiphoton imaging in both optical and mechanical systems to meet the demands of today.

Objective dedicated to multiphoton imaging

CFI75 Apochromat 25xW MP objective features chromatic aberration correction over a broad wavelength range from 405 to 950 nm, high NA (numerical aperture) (1.10) and longer working distance (2.0 mm), and compatibility with water immersion and water dipping.

High-sensitivity multiphoton detector (NDD)

Newly developed episcopic NDD (non-descanned detector) unit incorporates a detector that efficiently senses weak signals from deep areas of live specimens. In combination with a diascope NDD unit, transmitted signals can be also detected.

Retrofittable focusing nosepiece mechanism

Microscopes can be modified by switching the focusing stage and focusing nosepiece, enabling fixed-stage configuration to meet demands of experiments such as *in vivo* imaging.

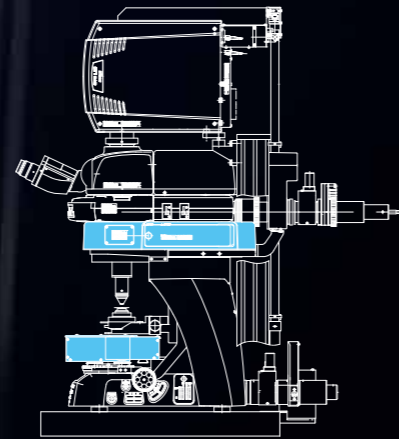

Mounted episcopic NDD unit and diascope NDD unit

Ni-E

In vivo imaging

Two-photon imaging

Photo activation



Enhanced system expandability provides the best solution

Ni series accessories are segmented by function, allowing you to select required units and flexibly combine them to create lean and effective system configurations.

System configuration for acquiring multi-stained specimen images

The motorized epi-fluorescence cube turret shutter, which helps to reduce photobleaching of specimens, is easily operated with a convenient remote control pad.

Images are automatically acquired by controlling the motorized accessories, including the epi-fluorescence cube turret according to the camera settings such as exposure time, camera gain, and time interval.

This configuration is recommended for those who conduct mostly fluorescent observations rather than brightfield observations.



Configuration of manual microscope Ni-U with motorized epi-fluorescence cube turret, epi-fluorescence attachment, motorized septuple nosepiece, digital camera DS-Qi1 and DS-Fi2, control unit DS-L3, simple remote control pad, control box B

System configuration for acquiring pathological specimen images

Optimal brightness can be automatically adjusted with objective changeover, eliminating the need for manual adjustment. As operations for optical zooming can be controlled from the control unit DS-L3, images of the desired angle of field can be captured while maintaining image quality.

Configuration of motorized microscope Ni-E with motorized quadocular tilting tube, motorized DSC zooming port, motorized ND filter, digital camera DS-Fi2, motorized XY stage and joystick, control unit DS-L3, control box A



Versatile microscopes meet all demands

Manual and motorized models

To meet diverse user demands for operability, system expandability and motorized control, Nikon provides two Ni series models. The Ni-U, which has compatibility with some motorized accessories, is the manual model suitable for high-quality image observation and digital imaging. The Ni-E is a fully motorized model that is efficient for experiments requiring comprehensive control of various devices, such as photoactivation units and confocal systems.

Ni-U (manual model)

- Ergonomic tube and stage height adjustment mechanism allow comfortable viewing positions.
- Stratum structure and sturdy design improve expandability.
- Motorized nosepiece, motorized epi-fluorescence cube turret, motorized shutter, motorized excitation filter wheel can be utilized.



Ni-U configured with an ergonomic binocular tube



Ni-E configured with a motorized epi-fluorescence cube turret and motorized universal condenser

Ni-E (motorized model)

- High-precision motorized focusing
- Broad range of motorized accessories that can be used in combination.
- Observation methods can be changed at a simple push of a button.
- Stratum structure and sturdy design improve expandability.
- 3D ergo design buttons with improved operability are located close together for speedy operations.
- Microscope settings in use can be verified on the display.
- Optimized for multiphoton excitation imaging
- Two focusing mechanism options: focusing stage and focusing nosepiece

Ni-E provides fully motorized operations

Automatic adjustment with objective changeover

Condenser, aperture and field diaphragm, and ND filter are automatically set to the optimal position during objective changeover. In addition, stage XYZ travel amount per handle rotation and parfocal distance deviation correction are automatically adjusted. Microscope settings can also be manually adjusted.

Observation mode changeover

Observation methods such as brightfield, DIC, phase contrast and fluorescence can be designated individual buttons, enabling changes to be made at the push of a button. This is particularly useful when the same sample is imaged with multiple observation methods.

High-precision motorized focusing

High-precision Z-focus incorporated by the Ni-E provides accurate height information required for use with confocal laser microscopes. Individual coarse and fine focus knobs provide enhanced ease of operation.



Technologies supporting the Ni series

Supreme optical performance

As a light microscope manufacturer, Nikon has cultivated high technical capabilities and confidence. With its advanced technologies extending from optical glass production to lens design, fabrication, coating and processing, Nikon provides unsurpassed optical performance.

High-performance objective lens

● CFI Plan Apochromat λ series

With remarkably high NA, greatly improved transmission in the long wavelength range thanks to Nikon proprietary Nano Crystal Coat, and chromatic aberration correction over 435 to 850 nm, these objectives are ideally suited not only for brightfield and DIC observations but also for fluorescent observations. These lenses allow acquisition of bright and clear images at any wavelength for near-IR imaging and multi-color fluorescence imaging. Because bright images can be captured even with a weak excitation light, damage to a specimen is minimized.



Nano Crystal Coat

This anti-reflective coating that consists of nanometer-size particles is based on semiconductor manufacturing technology and is also used for Nikon camera lenses. The coarse structure with particles arranged in a spongy construction with uniform spaces between them enables extremely low refractive indices.

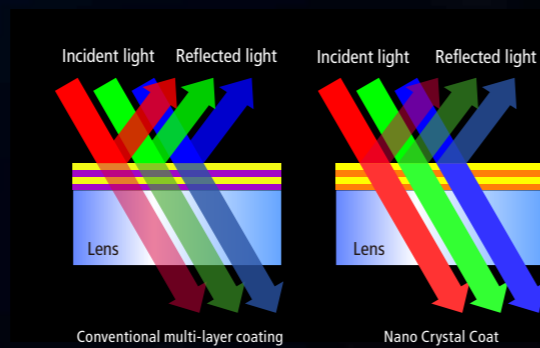

● Water dipping objective lenses

With a long working distance and high NA, these objectives provide excellent transmission in near IR wavelength range. The axial chromatic aberration of 40x and 60x objectives has been corrected to up to 850 nm, allowing high-resolution images of minute structures in thick specimens during IR-DIC observation. The 25xW MP and 100x objectives feature high NA (1.1) and a long working distance (2.0 mm). With chromatic aberration corrected in the IR region, these objectives are ideal for multiphoton excitation observation. In addition, by employing a mechanism to compensate for the changes in spherical aberration that occur at different temperatures and depths of observation points, clear images of areas deep within a thick specimen can be captured.



Uniformly bright illumination

The "fly-eye" lens is ideally suited to diascopic illumination optical systems. Uniform and bright illumination up to the viewfield periphery is provided at any magnification.

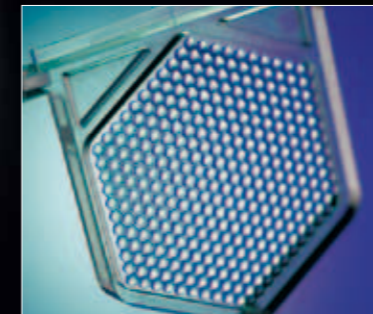

Fluorescence noise elimination

Nikon's proprietary noise terminator mechanism is employed in the epi-fluorescence cube turret and filter cubes. The S/N ratio has been dramatically improved by thoroughly eliminating stray light in the filter cubes, allowing images of weak fluorescent signals to be captured with high contrast and brightness.

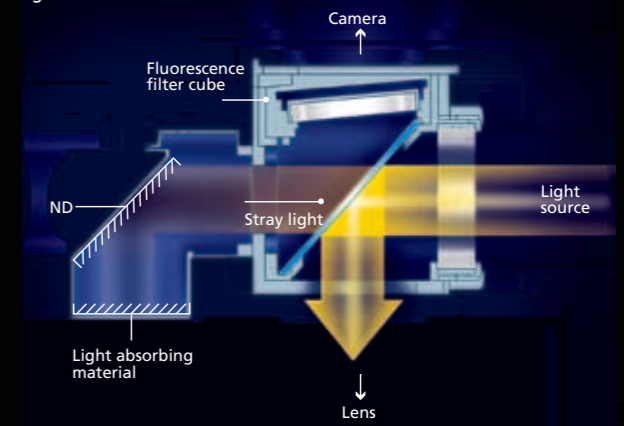

Excellent image acquisition with all observation methods

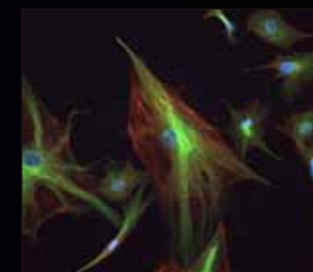

Epi-fluorescence observation

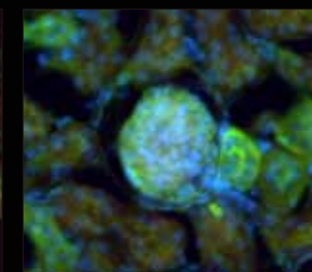

DIC (Differential Interference Contrast) observation

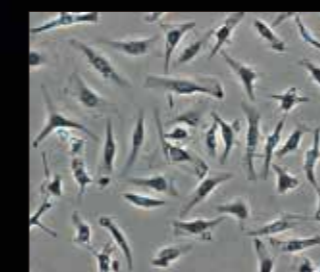
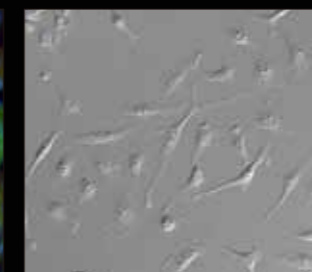

Phase contrast observation

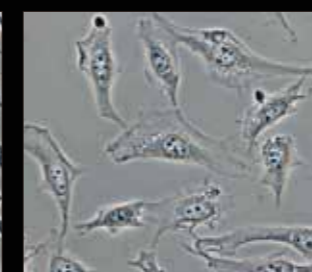

Brightfield observation



Ultimate ease, speed and clarity in imaging

Digital imaging

The Ni series can be controlled in conjunction with a Digital Sight series digital camera, facilitating effortless digital imaging. Images can be captured with a dedicated button on the microscope body, the touch panel on the camera control unit, or the software GUI on a PC, depending on your preference.

● Image capture button

Images can be acquired by simply pressing the image capture button located on the microscope base, without removing your eyes from the eyepieces.



● Stand-alone control unit DS-L3

Stand-alone control unit DS-L3 allows the Digital Sight series digital camera to be set up and operated without a PC connection. It also enables image acquisition from a PC through a network. The DS-L3 is firmware based, and therefore will not compromise your facility's network.

- Optimal imaging parameters for each observation method can be selected using icons and simple measurements can be taken.
- Camera, motorized microscope functions and peripheral devices can be comprehensively controlled.
- Microscope status data, such as objective lens, fluorescent filter cube and condenser information, is automatically saved along with the captured image when a motorized or intelligent unit is attached.
- Operations can be controlled with a mouse or a touch panel operated by touch or stylus pen.
- Required icons can be selected and laid out as desired.



Camera/microscope control



Microscope control

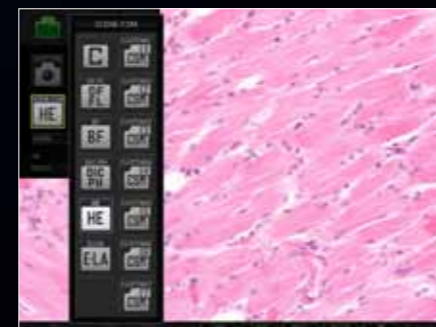

Scene mode icons

● Integrated imaging software

Nikon's imaging software NIS-Elements employs a single platform to allow stress-free operations, from image capture through to comprehensive control of camera, microscope and peripheral devices, to image processing, measurement, data management and analysis.

Digital Sight series digital cameras

A wide array of models with high sensitivity, high resolution, high speeds and faithful color reproduction are available to meet all research needs and purposes.

● High-sensitivity cooled monochrome camera head DS-Qi1

The new CCD drive circuit reduces readout noise. The cooling mechanism reduces heat-induced noise, allowing the capture of weak fluorescence signals. Furthermore, there is a high frame rate of up to 48 fps and a high quantitative linearity within 2%.



● High-definition cooled color camera head DS-Fi1c

Equipped with a 5-megapixel CCD. The cooling mechanism reduces heat-induced noise, making it ideal for fluorescent image acquisition.



● Ultrahigh-resolution cooled color camera head DS-Ri1

Provides the 12.7-megapixel equivalent, 2200 TV line high definition. Smooth live image display at max. 32 fps makes focusing easy. Superior color reproduction capabilities allow recording of accurate specimen colors. The cooling mechanism reduces heat-induced noise in fluorescent images.



● High-definition color camera head DS-Fi2

Equipped with a 5-megapixel CCD. Displays live images at max. 21 fps. Minute structures can be captured in brightfield, phase contrast and DIC observations.



Confocal imaging

The Ni series is sturdy enough for the incorporation of a confocal scanner. The broad flux of light allows the capture of bright confocal images.

● Multiphoton confocal microscope A1R MP

A1R MP is capable of high-speed multiphoton imaging up to 420 fps. The NDD enables deep specimen imaging with high sensitivity. High-speed, accurate GFP/YFP unmixing is possible with NDD.

● Confocal microscope A1R/A1

A1 incorporates a high-definition (up to 4096 x 4086 pixels) non-resonant scanner. A1R also incorporates a high-speed (up to 420 fps) resonant scanner, enabling simultaneous photo activation and imaging.

● Confocal microscope C2

C2 features a compact design and high operability, and it supports 4-channel simultaneous acquisition. It provides various imaging such as image stitching (large images).

● Spectral imaging confocal microscope A1Rsi/A1si/C2si

By incorporating a spectral detector, a wide wavelength spectrum of 320 nm can be acquired with a single scan. Closely overlapping spectra can be unmixed cleanly with no crosstalk.

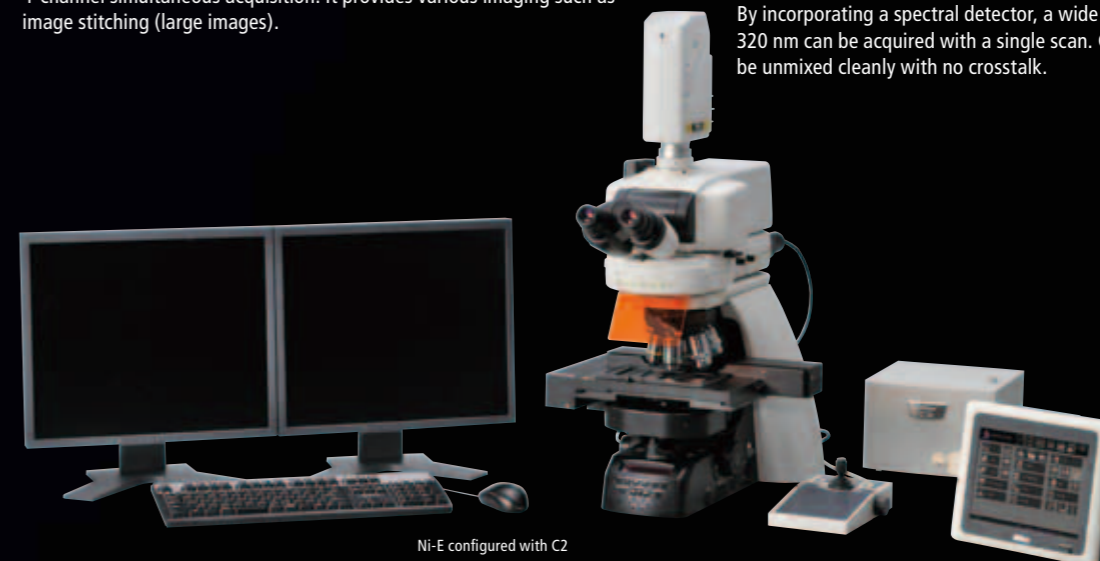

Ni-E configured with C2

Elegant design with absolute comfort

Our design goal for the Ni series was to provide physical and mental comfort during use. Straight lines and flat surfaces that are traditionally employed in microscope design do not exist in nature, so they induce a feeling of tension while seated in front of the microscope. The Ni series employs a modern organic design in the microscope wing that adds a gentle beauty while reducing stress during lengthy observations.

When designing the Ni series, Nikon collaborated with Akio Shindate, previously involved in the design of Nikon SLR cameras from the early stage of concept building. Through this collaboration with Shindate, who excels at unique ideas and stylish designs, Nikon has produced innovative new microscopes that combine function with beauty.



Akio Shindate (Director, VO Corporation Ltd.)

Based in the United Kingdom. After graduating from a U.S. university, worked for a design company in London and participated in a great number of international projects. Became independent and established VO Corporation in 2000. Active in design of automobiles and electronic devices for clients mainly in Japan, the United States and Europe.



Design for function

The Ni series embodies the basic spirit of a product design for "minimizing user fatigue".

- **3D ergo design for comfortable touch-type operations**
Buttons on microscope sides are angled to allow touch-type operations during observation.
- **Easy to see display**
Microscope settings are shown on a display that can be easily viewed from the observation position.
- **Small footprint**
Space-saving microscope base assures larger work space.



Contrast between elegance and sharpness

The white microscope wings feature an innovative and elegant curved design. In contrast, the rectilinear and black microscope base reflects Nikon's image of high quality and high performance. This new design will also be employed in all accessories and Ci series clinical and laboratory microscopes, and will continue in future models.

Wide array of accessories finely segmented by function



Motorized quadocular tilting tube (Ni-E)

Motorized changeover of optical paths is possible. Eyepiece inclination can be adjusted from 15° to 35°.



Motorized DSC zooming port (Ni-E)

A digital camera can be mounted on the camera port. A motorized 0.6x - 2.0x zoom optical system is incorporated.



Motorized ND filter (Ni-E)

Brightness is automatically optimized with the changeover of the motorized nosepiece. Motorized adjustment of desired brightness is also possible.



Motorized XY stage (Ni-E)

Effective for applications that require highly accurate positioning, such as photo-activation imaging and FISH.



Joystick for motorized stage (Ni-E)

Makes control of motorized XY stage possible.



Ergo controller (Ni-E)

In addition to motorized microscope operation, XYZ control of stage is possible with similar operational ease as that of an actual microscope.



Motorized universal condenser Dry (Ni-E)

High-speed motorized changeover of condenser lenses for brightfield, phase contrast, DIC and simple darkfield observations is possible.



Motorized barrier filter wheel (Ni-E)

Barrier filter positions (7 positions—using 25 mm filters) can be changed at a high speed of 0.2 sec. per position.



Motorized excitation filter wheel (Ni-E, Ni-U)

Excitation filter positions (8 positions—using 25mm filters) can be changed at a high speed of 0.15 sec. per position.



Photoactivation unit (Ni-E, Ni-U)

Laser light photo activation and episcopic illumination are possible. Both the photoactivation unit and the confocal system can be used with a single laser source.



Motorized septuple nosepiece (Ni-E, Ni-U)

Objective magnification is automatically saved along with the captured image.



Motorized sextuple DIC nosepiece (Ni-E, Ni-U)

Objective magnification is automatically saved along with the captured image. Built-in prism/analyzer plate slot.



Motorized epi-fluorescence cube turret (Ni-E, Ni-U)

Noise terminator provides high S/N ratio. Six filter cubes can be installed. Either an epi-fluorescence attachment or a photoactivation unit can be attached.



Motorized shutter (Ni-E, Ni-U)

High-speed shutter control is possible. The shutter can be attached to diasopic and episcopic illumination systems.



Simple remote control pad (Ni-U)

Motorized operation of nosepiece, epi-fluorescence cube turret and shutter is possible.

System diagram: Ni-E focusing stage type

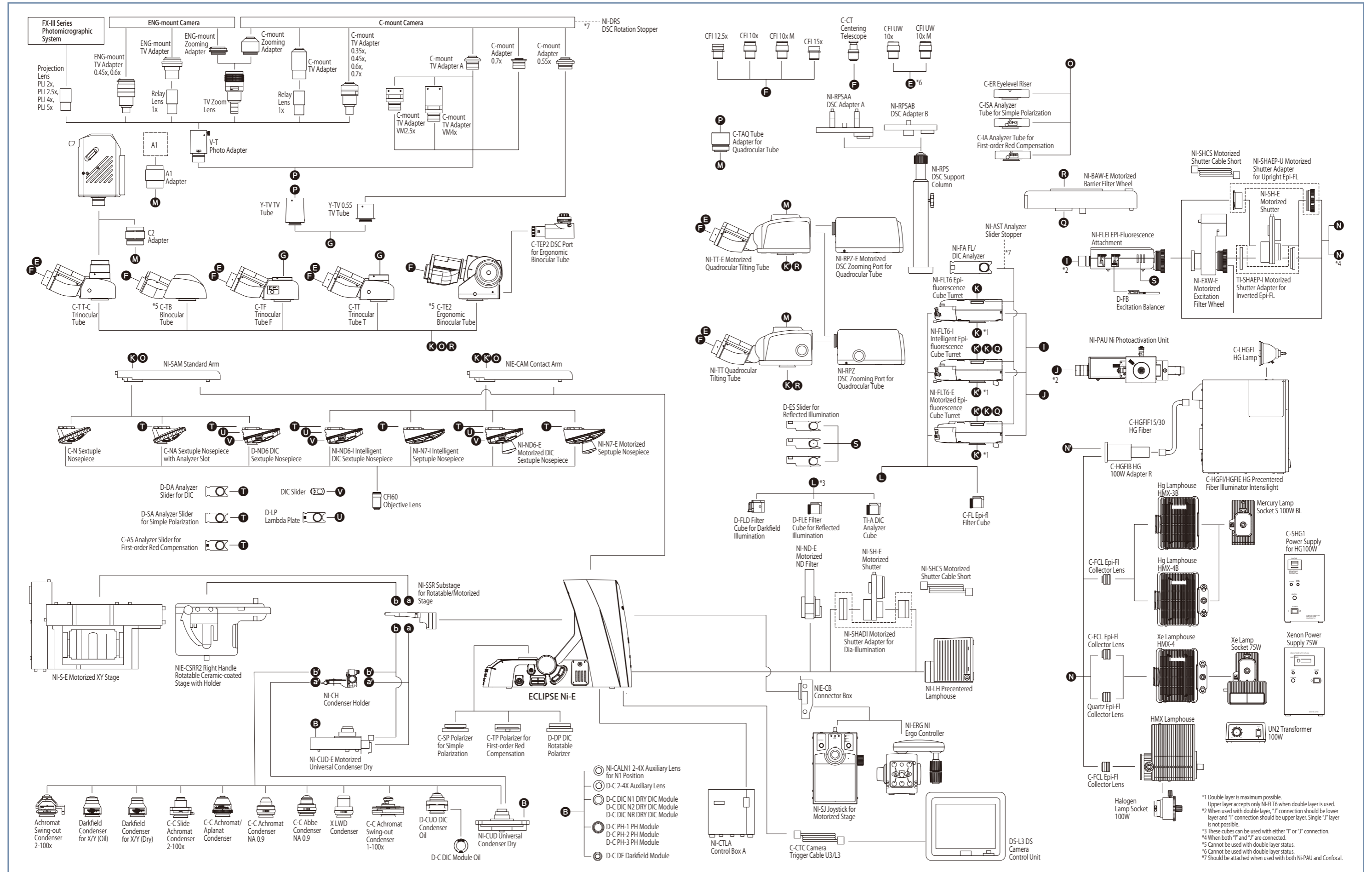

System diagram: Ni-E focusing nosepiece type

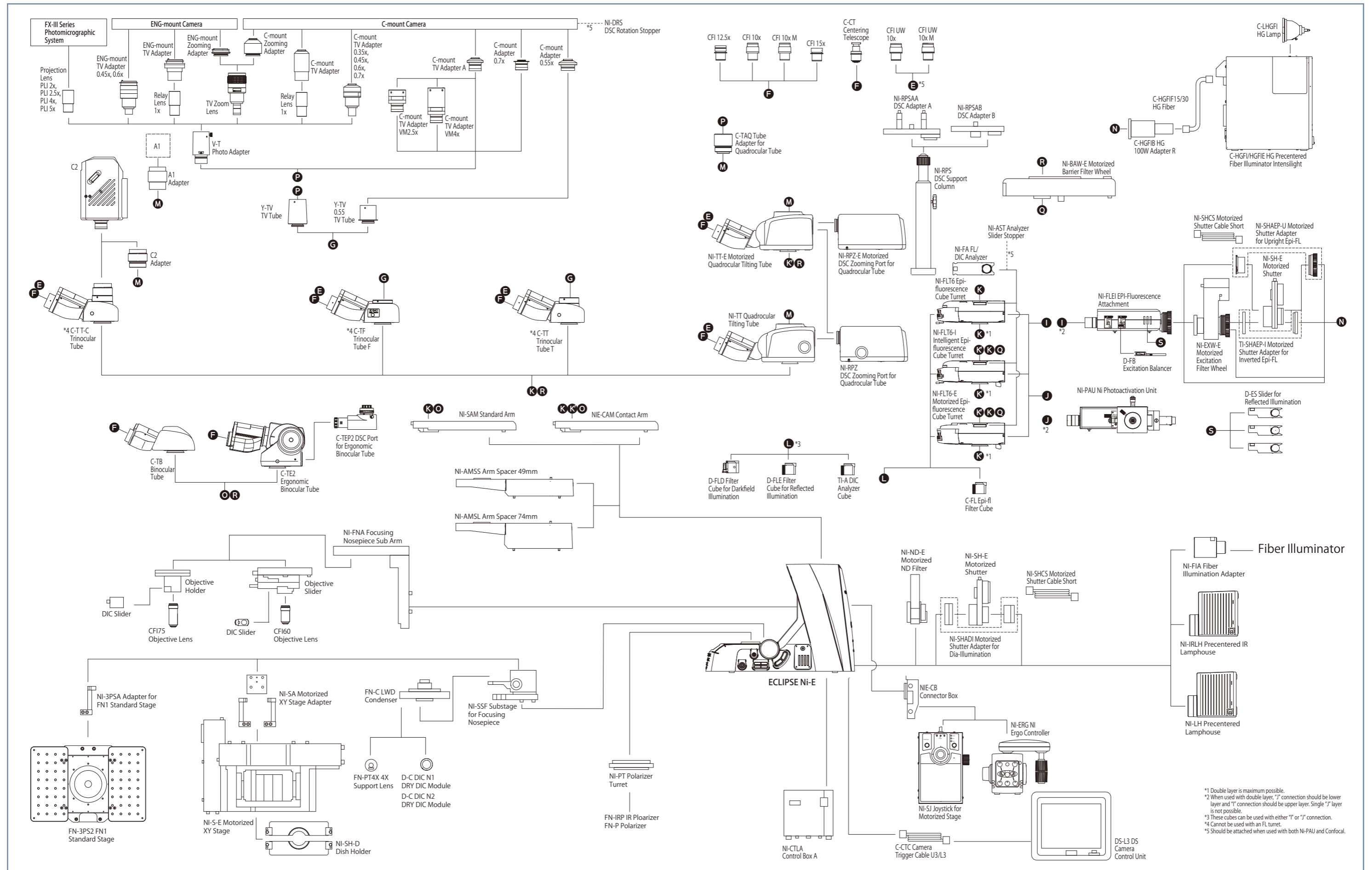

*1 Double layer is maximum possible.
 *2 When used with double layer, "J" connection should be lower layer and "I" connection should be upper layer. Single "J" layer is not possible.
 *3 These cubes can be used with either "I" or "J" connection.
 *4 Cannot be used with an FL turret.
 *5 Should be attached when used with both Ni-PAU and Confocal.

System diagram: Ni-U

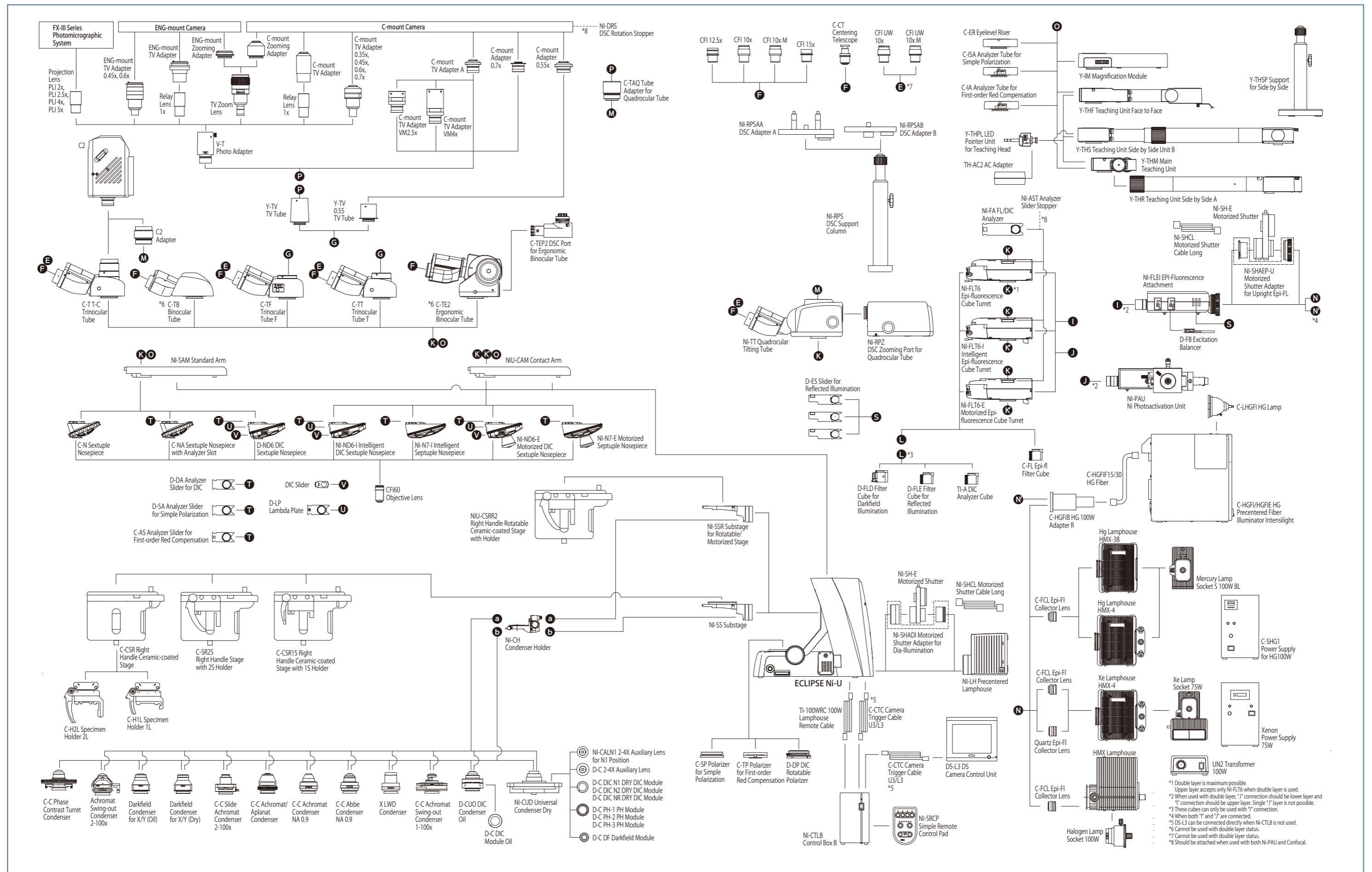

*1 Double layer is maximum possible. Upper layer accepts only NI-FLT6 when double layer is used.
 *2 When used with double layer, "J" connection should be lower layer and "T" connection should be upper layer. Single "T" layer is not possible.
 *3 These cubes can only be used with "T" connection.
 *4 When both "T" and "J" are connected.
 *5 DS-L3 can be connected directly when NI-CTLB is not used.
 *6 Cannot be used with double layer status.
 *7 Cannot be used with double layer status.
 *8 Should be attached when used with both NI-PAU and Confocal.

Specifications

Ni-E			
Focusing mechanism	Focusing stage	Focusing nosepiece	
Main body	Optical system	CFI60 infinity optical system	
	CFI60 and CFI75 infinity optical systems		
	Illumination	12V100W halogen lamp, power supply from control box A Built-in fly-eye lens Built-in NCB11/ND8/ND32 filters (in/out possible, detachable, one additional filter mountable) and diffuser (in/out not possible, non-detachable) Motorized ND filter unit for light intensity control available as option	
	Controls	Transmitted light on/off switch, intensity control dial (Preset function provided) NCB11/ND8/ND32 filter in/out switches Motorized control switches (field diaphragm, aperture diaphragm, objective changeover, objective escape, focus reset, fluorescence cube turret, excitation light shutter, optical path changeover, observation mode changeover, microscope status display changeover) Image capture button Ergo controller (option)	
	Focusing	Motorized coaxial coarse/fine focusing Built-in linear encoder, resolution: 0.05 μ m	
		Focusing stroke (from focus point): upward 2 mm, downward 13 mm Escape function as refocusing mechanism	Focusing stroke (from focus point): upward 12 mm, downward 3 mm Escape function as refocusing mechanism
Eyeiece lens (F.O.V.)	10x (22 mm), 10xM photomask (22 mm), 12.5x (16 mm), 15x (14.5 mm), UW10x (25 mm), UW10xM photomask (25 mm)		
Eyeiece tube (Light distribution)	Binocular tube, F.O.V. 22 Trinocular tube F, F.O.V. 22/25* (eyepiece/port: 100/0, 0/100) Trinocular tube T, F.O.V. 22/25* (eyepiece/port: 100/0, 20/80, 0/100) Ergonomic binocular tube, F.O.V. 22, inclination angle: 10-30, tube extension up to 40 mm (when DSC port is attached, eyepiece/port: 100/0, 50/50) Quadrocular tilting tube, Motorized quadrocular tilting tube, F.O.V. 22/25*, inclination angle: 15-35 (eyepiece/upper port/ rear port: 100/0/0, 0/100/0, 0/0/100) * When using layered epi-fluorescence cube turrets, or layered epi-fluorescence cube turret and motorized barrier filter wheel, F.O.V. is 22.		
Arm	Standard arm, Contact arm: For motorized control		
Nosepiece	Motorized septuple nosepiece, Motorized sextuple DIC nosepiece, Intelligent septuple nosepiece, Intelligent sextuple DIC nosepiece, Sextuple DIC nosepiece, Sextuple nosepiece with analyzer slot, Sextuple nosepiece	<ul style="list-style-type: none"> Sliding nosepiece (for CFI60 objectives): Front/back sliding objective changeover, duple nosepiece, DIC slider insertable Single objective holder (for CFI75 objectives): DIC slider insertable 	
Stage	Rotatable ceramic-coated stage (Centerable, rotation angle 202° , with specimen holder for 2 slides) Cross travel 78(X) x 54(Y) mm, with calibrations, stage handle height and torque adjustable	<ul style="list-style-type: none"> 3-plate mechanical stage Cross travel 66(X) x 55(Y) mm 	
	Motorized XY Stage Observation area: 66(X) x 52(Y) mm, resolution: 0.1 μ m Movement speed: 25 mm/sec Dish holder (option)		
Substage	For motorized universal condenser and stages (rotatable stage, motorized XY stage) Attachable to the focusing unit of microscope	For LWD condenser and stages (3-plate mechanical stage, motorized XY stage) Attachable to the base of microscope	
Condenser	Motorized universal condenser dry: Optical modules for DIC, phase contrast, darkfield observations can be mounted. Universal condenser dry, Abbe condenser NA 0.9, Achromat condenser NA 0.9, Darkfield condenser (oil or dry), Achromat/aplanat condenser NA 1.4, X LWD condenser, Slide achromat condenser 2-100x, Achromat swing-out condenser 2-100x, Achromat swing-out condenser 1-100x, DIC condenser (oil)	LWD condenser NA: 0.78, OD: 82 mm DIC and oblique light observations possible	
Condenser holder	For manual condensers, equipped with condenser focusing knob and condenser centering screw, attachable to substage	Condenser holder with condenser focusing knob and condenser centering screw is included with the substage	
Input rating	500 VA (With max. halogen lamp and full range of motorized options attached)		
Weight (approx.)	25 kg (with motorized quadrocular tilting tube and fluorescent unit)	47 kg (with motorized quadrocular tilting tube and photoactivation unit)	

Ni-U		
Main body	Optical system	CFI60 infinity optical system
	Illumination	12V100W halogen lamp Built-in fly-eye lens Preset switch Built-in NCB11/ND8/ND32 filters (in/out possible, detachable, one additional filter mountable) and diffuser (in/out not possible, non-detachable)
	Controls	Transmitted light on/off switch, intensity control dial (Preset function provided) NCB11/ND8/ND32 filter in/out switches Image capture button Simple remote control pad (option)
	Focusing	Manual coaxial coarse/fine focusing (Minimum fine reading: 1 μ m) Focusing stroke (from focus point): upward 3 mm, downward 26 mm Coarse: 7.8 mm/rotation, fine: 0.1 mm/rotation
	Eyeiece lens (F.O.V.)	10x (22 mm), 10xM photomask (22 mm), 12.5x (16 mm), 15x (14.5 mm), UW10x (25 mm), UW10xM photomask (25 mm)
	Eyeiece tube (Light distribution)	Binocular tube, F.O.V. 22 Trinocular tube F, F.O.V. 22/25* (eyepiece/port: 100/0, 0/100) Trinocular tube T, F.O.V. 22/25* (eyepiece/port: 100/0, 20/80, 0/100) Ergonomic binocular tube, F.O.V. 22, inclination angle: 10-30, tube extension up to 40 mm (when DSC port is attached, eyepiece/port: 100/0, 50/50) Quadrocular tilting tube, F.O.V. 22/25*, inclination angle: 15-35 (eyepiece/upper port/rear port: 100/0/0, 0/100/0, 0/0/100) *When using layered epi-fluorescence cube turrets, F.O.V. is 22.
Arm	Standard arm, Contact arm: For motorized control	
Nosepiece	Motorized septuple nosepiece, Motorized sextuple DIC nosepiece, Intelligent septuple nosepiece, Intelligent sextuple DIC nosepiece, Sextuple DIC nosepiece, Sextuple nosepiece with analyzer slot, Sextuple nosepiece	
Stage	Stage with specimen holder for 2 slides (dry-film coated), Ceramic-coated stage with specimen holder for 1 slide, Ceramic-coated stage without specimen holder (specimen holder for 2 slides or 1 slide can be attached) , Rotatable ceramic-coated stage with specimen holder for 2 slides (Centerable, rotation angle 202°) Cross travel 78(X) x 54(Y) mm, with calibrations, stage handle height and torque adjustable	
Substage	Two types: for rotatable stage and non-rotatable stage Attachable to focusing unit of microscope	
Condenser	Universal condenser dry, Abbe condenser NA 0.9, Achromat condenser NA 0.9, Darkfield condenser (oil or dry), phase contrast condenser, Achromat/aplanat condenser NA 1.4, X LWD condenser, Slide achromat condenser 2-100x, Achromat swing-out condenser 2-100x, Achromat swing-out condenser 1-100x, DIC condenser (oil)	
Condenser holder	Equipped with condenser focusing knob and condenser centering screw, attachable to substage	
Input rating	170 VA (Ni-U base only): With max. halogen lamp 100 VA (Control box B only): With full range of motorized options attached	
Weight (approx.)	20 kg (Ergonomic binocular tube, for brightfield observation)	

Dimensional diagram

Ni-E (for use with focusing nosepiece)

Configured with an Ni photoactivation unit, two-tiered motorized epi-fluorescence cube turret and motorized quadocular tilting tube

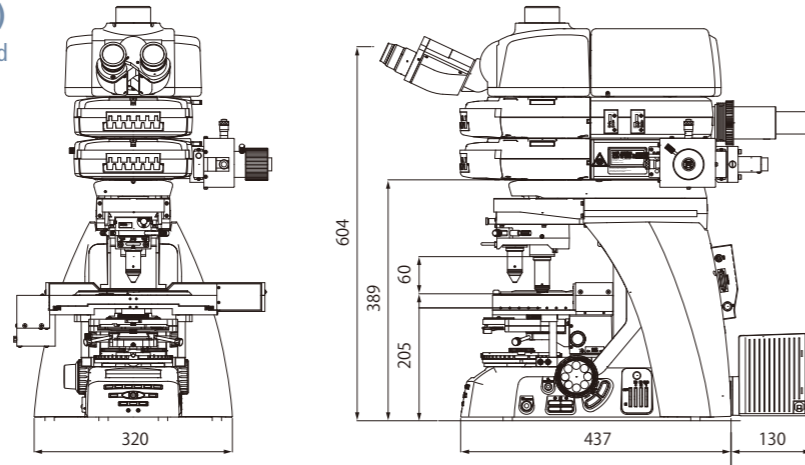

Ni-U

Configured with a motorized epi-fluorescence cube turret and quadocular tilting tube

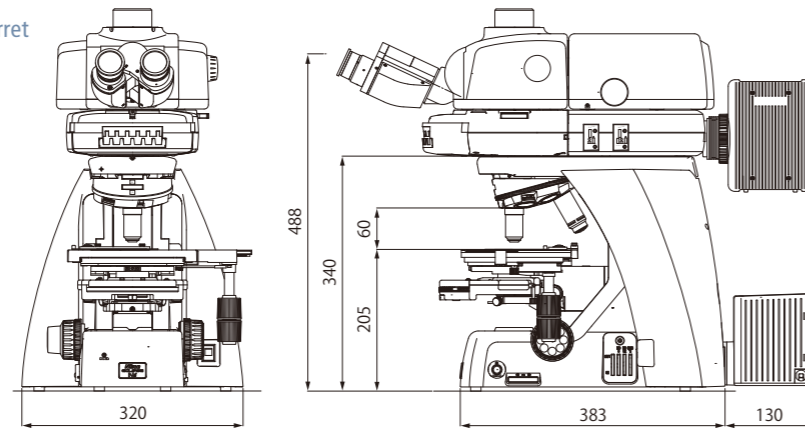

Ni-U

Configured with an ergonomic binocular tube and DSC port

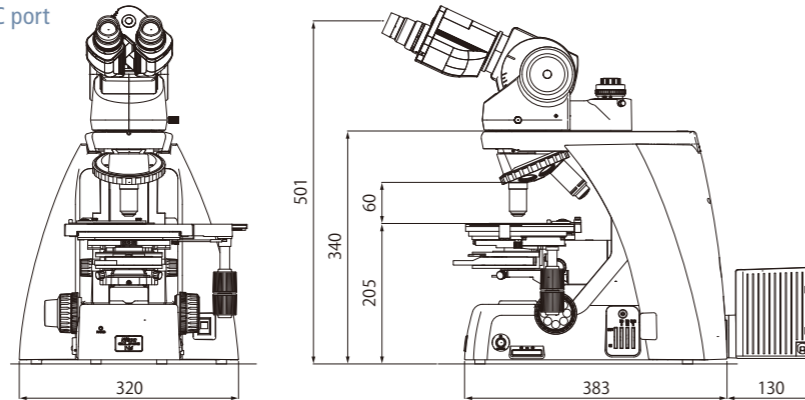

Unit: mm



Company names and product names appearing in this brochure are their registered trademarks or trademarks.
 N.B. Export of the products* in this brochure is controlled under the Japanese Foreign Exchange and Foreign Trade Law.
 Appropriate export procedure shall be required in case of export from Japan.
 *Products: Hardware and its technical information (including software)
 Monitor images are simulated.

Specifications and equipment are subject to change without any notice or obligation on the part of the manufacturer. August 2011 ©2011 NIKON CORPORATION

 WARNING	TO ENSURE CORRECT USAGE, READ THE CORRESPONDING MANUALS CAREFULLY BEFORE USING YOUR EQUIPMENT.
--	--



NIKON CORPORATION

Shin-Yurakucho Bldg., 12-1, Yurakucho 1-chome, Chiyoda-ku, Tokyo 100-8331, Japan
 phone: +81-3-3216-2375 fax: +81-3-3216-2385
<http://www.nikon.com/instruments/>

NIKON INSTRUMENTS INC.

1300 Walt Whitman Road, Melville, N.Y. 11747-3064, U.S.A.
 phone: +1-631-547-8500; +1-800-52-NIKON (within the U.S.A. only)
 fax: +1-631-547-0306
<http://www.nikoninstruments.com/>

NIKON INSTRUMENTS EUROPE B.V.

Laan van Kronenburg 2, 1183 AS Amstelveen, The Netherlands
 phone: +31-20-44-96-300 fax: +31-20-44-96-298
<http://www.nikoninstruments.eu/>

NIKON INSTRUMENTS (SHANGHAI) CO., LTD.

CHINA phone: +86-21-6841-2050 fax: +86-21-6841-2060
 (Beijing branch) phone: +86-10-5831-2028 fax: +86-10-5831-2026
 (Guangzhou branch) phone: +86-20-3882-0552 fax: +86-20-3882-0580

NIKON SINGAPORE PTE LTD

SINGAPORE phone: +65-6559-3618 fax: +65-6559-3668

NIKON MALAYSIA SDN. BHD.

MALAYSIA phone: +60-3-7809-3688 fax: +60-3-7809-3633

NIKON INSTRUMENTS KOREA CO., LTD.

KOREA phone: +82-2-2186-8400 fax: +82-2-555-4415

NIKON CANADA INC.

CANADA phone: +1-905-602-9676 fax: +1-905-602-9953

NIKON FRANCE S.A.S.

FRANCE phone: +33-1-4516-45-16 fax: +33-1-4516-45-55

NIKON GMBH

GERMANY phone: +49-211-941-42-20 fax: +49-211-941-43-22

NIKON INSTRUMENTS S.p.A.

ITALY phone: +39-055-300-96-01 fax: +39-055-30-09-93

NIKON AG

SWITZERLAND phone: +41-43-277-28-67 fax: +41-43-277-28-61



ISO 9001 Certified
NIKON CORPORATION
 Instruments Company



ISO 14001 Certified
NIKON CORPORATION

